

REV.	DESCRIPTION	DATE
-	RELEASE	Apr 11, 2003

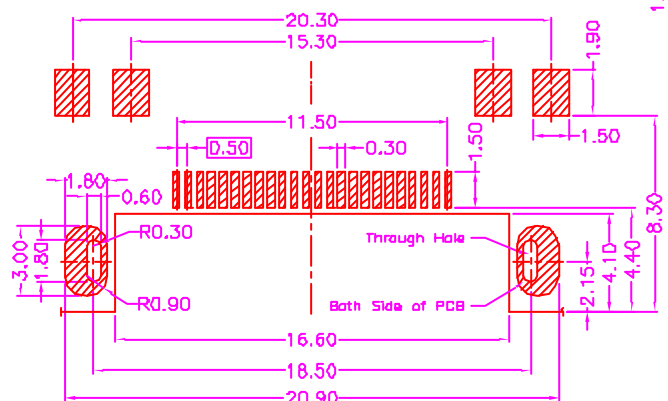
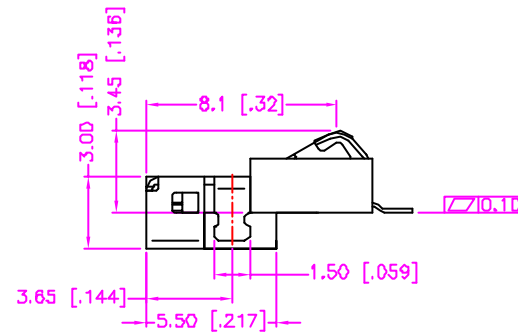
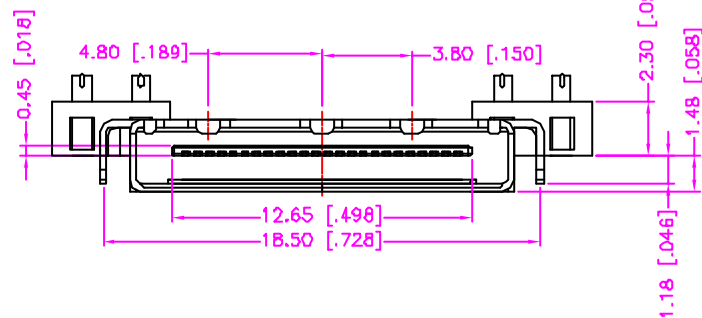
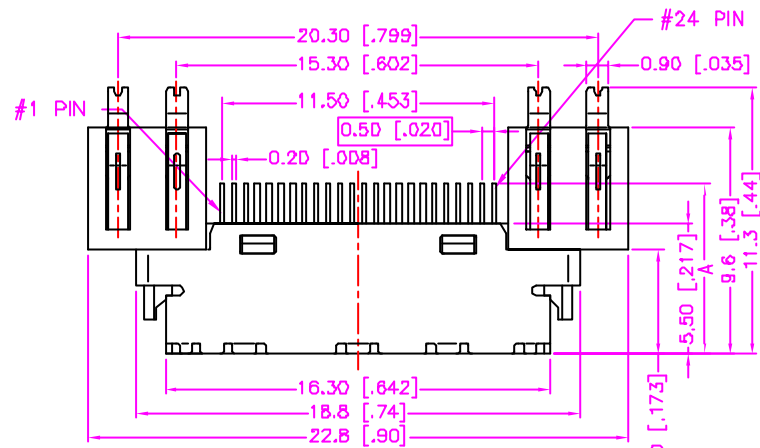

RECOMMEND P.C.B. LAYOUT  
TOLERANCE ±0.05  
TOP VIEW

### MATERIALS

- HOUSING : HI-TEMP. PLASTIC (UL 94V-0).
- TERMINAL : COPPER ALLOY, GOLD PLATED OVERALL.  
(t=0.20mm, SIGNAL TERMINAL; t=0.15mm, BATTERY TERMINAL)
- SHELL : STAINLESS STEEL, NICKEL PLATED. (t=0.30mm)

### SPECIFICATION

- CURRENT RATING : 1.0 AMP. MAX.
- DIELECTRIC WITHSTANDING VOLTAGE : 250V AC R.M.S. FOR ONE MINUTE.
- INSULATION RESISTANCE : 1000M OHMS MIN AT 250V DC.
- OPERATING TEMPERATURE : -40°C TO +85°C.

### ORDER INFORMATION

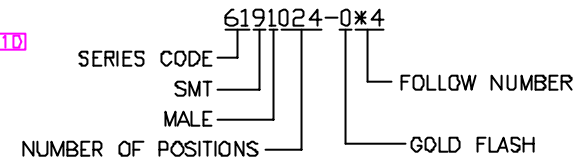

6.70 [0.264]	TYPE II	6191024-034
7.20 [0.283]	TYPE I	6191024-024
A	TYPE	PART NO.

TOLERANCE .0±0.3B [0.015] .00±0.25 [0.010] .000±0.15 [0.006] .0000±. ANG.=±3°		DRAWER <i>L88</i>		 ASTRON TECHNOLOGY CORP. NAME 0.5PH IN-PHONE 24P SLIM TYPE (D TYPE)
UNITS : mm [inch]		CHECK <i>Katherine</i>		
SCALE NGNE		APP'D <i>L90N</i>		
SIZE A4	SHEET 1 OF 1	PRODUCT SPEC. —	REV. A	DRAW NO. R6191024-0X4