

REV.	DESCRIPTION	DATE
—	RELEASE	Mar. 25, 2003
1		
2		

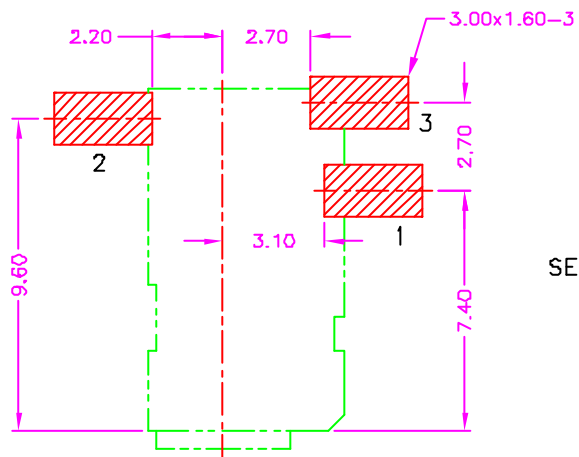
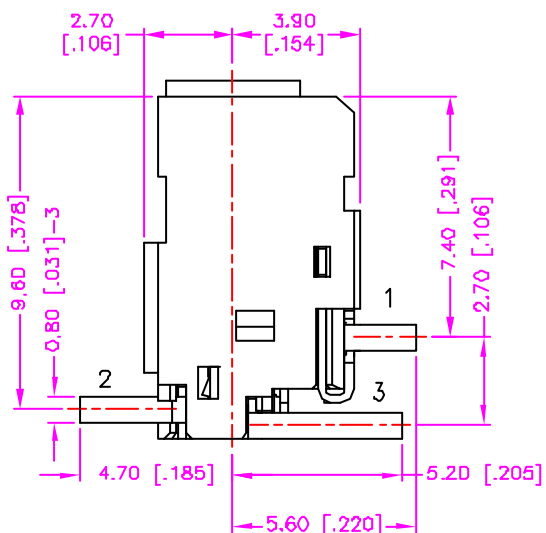
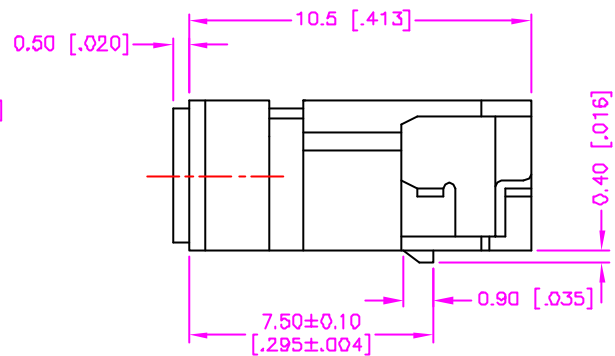
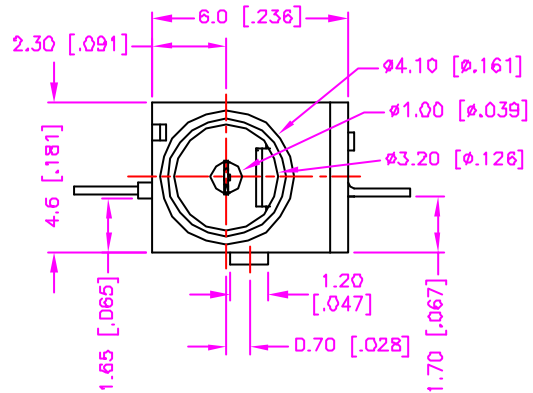

RECOMMEND P.C.B LAYOUT  
TOP VIEW

**MATERIALS**

1. HOUSING : HI.-TEMP. PLASTIC (UL 94V-0), BLACK.
2. CENTER PIN : BRASS, SILVER PLATING.
3. TERMINAL : COPPER ALLOY, SILVER PLATING.

**SPECIFICATION**

1. CURRENT RATING : 2 AMP. MAX.
2. DIELECTRIC WITHSTANDING VOLTAGE : 250V AC R.M.S. FOR ONE MINUTE.
3. INSULATION RESISTANCE : 100M OHMS MIN. AT 250V DC
4. CONTACT RESISTANCE : 50m OHMS MAX.
5. OPERATING TEMPERATURE : -25°C TO +85°C.
6. DURABILITY : 5000 CYCLES.
7. MATING FORCE : 0.3 ~ 2.0kgs.
8. UNMATING FORCE : 0.3 ~ 2.0kgs.
9. MAX. PROCESSING TEMPERATURE : 230°C FOR 30 ~ 60 SECONDS.

**ORDER INFORMATION**

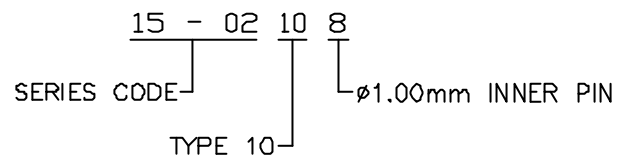

**SCHEMATIC**

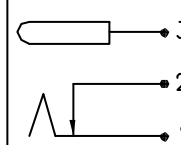

TOLERANCE .0=±.30 [.012] .00=±.20 [.008] .000=±.XXX .0000=±. ANG.=±3°	DRAWER <i>Katherlin</i>	<b>Astron</b> ASTRON TECHNOLOGY CORP.
UNITS : mm [inch]	CHECK <i>230X</i>	
SCALE NONE	SIZE A4	DRAW NO. C522-0209
SHEET 1 OF 1	REV. A	08005