

REV.	DESCRIPTION	DATE
—	RELEASE	Jan. 24, 2003
1		
2		

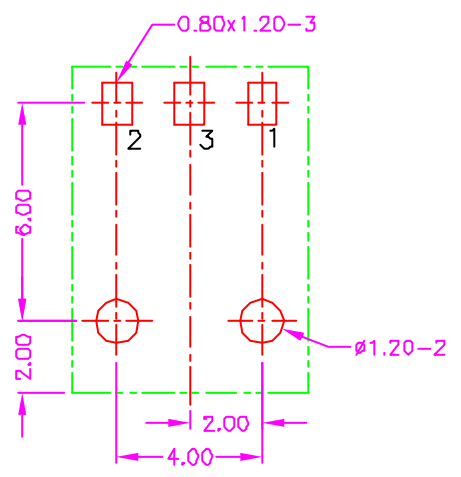
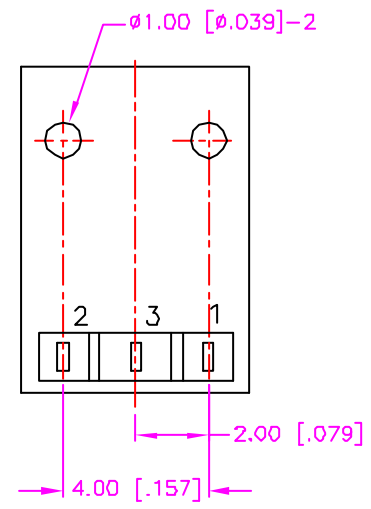
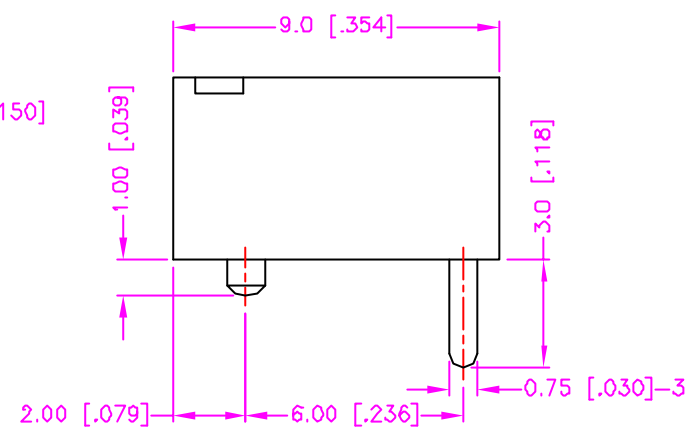
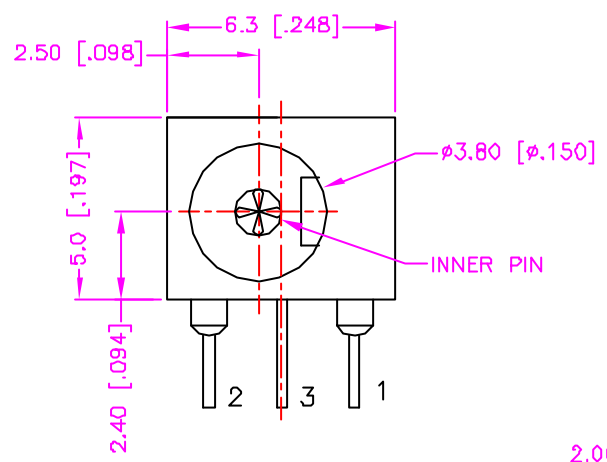

RECOMMEND P.C.B. LAYOUT  
TOP VIEW

### MATERIALS

- HOUSING : POLYAMIDE (UL 94V-0), BLACK.
- TERMINAL : COPPER ALLOY, TIN PLATING. (t=0.30mm)

### SPECIFICATION

- CURRENT RATING : 2 AMP. MAX.
- DIELECTRIC WITHSTANDING VOLTAGE : 250V AC R.M.S. FOR ONE MINUTE.
- INSULATION RESISTANCE : 100M OHMS MIN. AT 250V DC
- CONTACT RESISTANCE : 30m OHMS MAX.
- OPERATING TEMPERATURE : -25°C TO +85°C.
- DURABILITY : 5000 CYCLES.
- MATING FORCE : 0.3 ~ 3.0kgs.
- UNMATING FORCE : 0.3 ~ 3.0kgs.

### ORDER INFORMATION

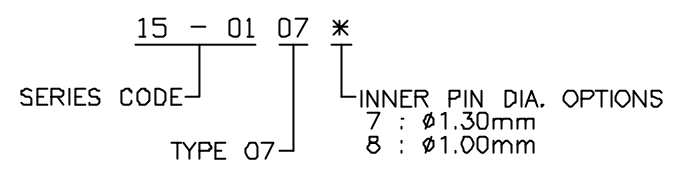

### SCHEMATIC

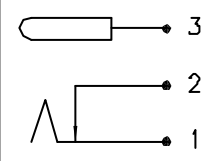

TOLERANCE .0 $\pm$ .30 [.012] .00 $\pm$ .20 [.008] .000 $\pm$ .XXX .0000 $\pm$ . ANG.= $\pm 3^\circ$	DRAWER <i>Katherlin</i> CHECK <i>LSON</i> APP'D <i>JUE</i>	 <b>ASTRON TECHNOLOGY CORP.</b> NAME DC POWER JACK P.C.B. MOUNT, FEMALE
UNITS : mm [inch] SCALE NONE   SIZE A4   SHEET 1 OF 1   REV. A	PRODUCT SPEC. 516-0007	
		08005