

| REV. | DESCRIPTION | DATE |
|------|-------------|---------------|
| — | RELEASE | Nov. 26, 2001 |
| 1 | DRAW MODIFY | Nov. 28, 2003 |
| 2 | | |

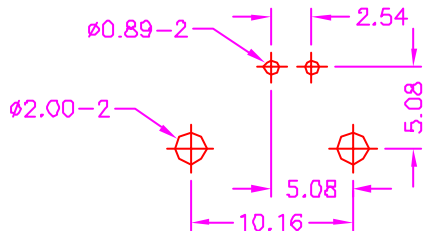

RECOMMEND P.C.B. LAYOUT
TOP VIEW

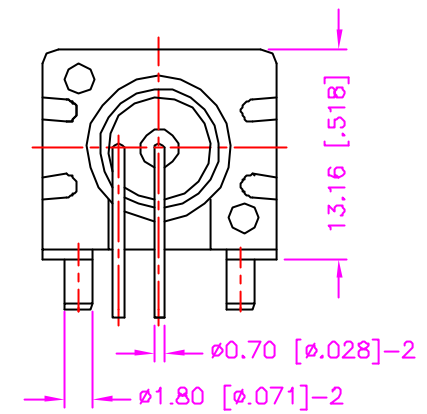
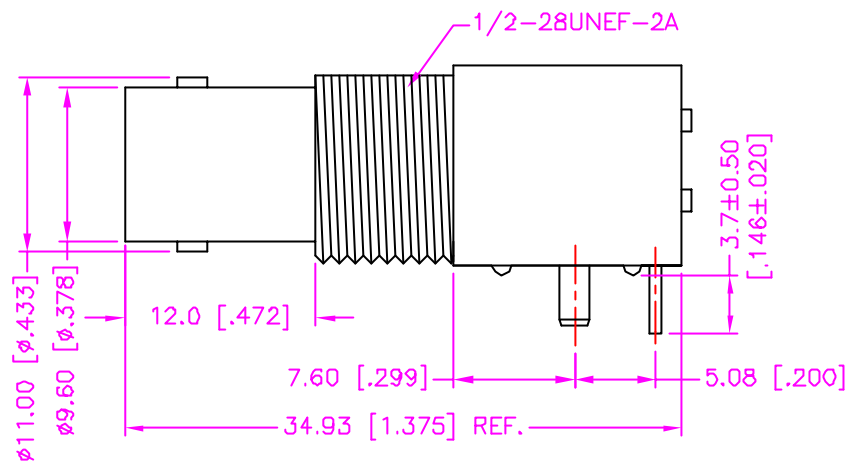
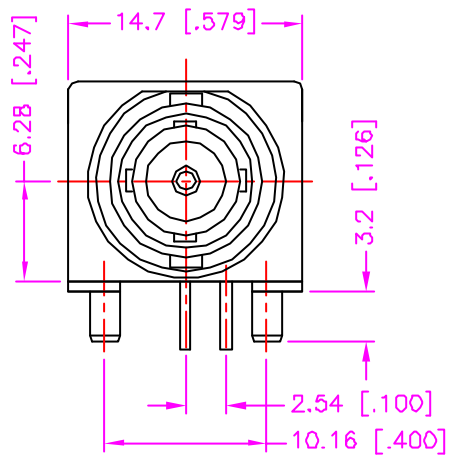
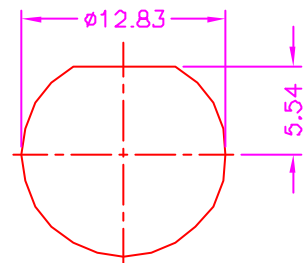

RECOMMEND PANEL CUTOUT

ORDER INFORMATION :

51 - 0104 C - ** *

SERIES CODE

HOUSING HEIGHT 13.16mm

CONNECTOR IMPEDANCE OPTIONS

50 : 50 OHMS
75 : 75 OHMS

HOUSING COLOR OPTIONS

W : WHITE
BLANK : BLACK

MATERIALS

1. HOUSING : POLYESTER (UL 94V-0).
2. INSULATOR : PE-606
3. BODY : ZINC ALLOY, NICKEL PLATING.
4. CENTER CONTACT : COPPER ALLOY, GOLD PLATING.
5. SOLDER TAIL : COPPER ALLOY, TIN PLATING.
6. POST : BRASS, TIN PLATING.

SPECIFICATION

1. DIELECTRIC WITHSTANDING VOLTAGE : 1000V AC R.M.S. FOR ONE MINUTE.
2. INSULATION RESISTANCE : 5000M OHMS MIN. AT 1000V DC.
3. CONTACT RESISTANCE : 30m OHMS MAX.
4. OPERATING TEMPERATURE : -25°C TO +85°C.
5. DURABILITY : 500 CYCLES.
6. FREQUENCY RANGE : 0~2 GHz.
7. VOLTAGE PEAK MAX. : 500V.

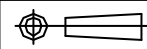
| | | | |
|--|----------------------------|--|--|
| TOLERANCE .0±.38 [.015] .00±.25 [.010] .000±.XXX .0000±. ANG.=±3° | DRAWER <i>Katherlin</i> | Astron ASTRON TECHNOLOGY CORP. | |
| | CHECK <i>SUB</i> | | NAME BNC CONNECTOR ALL PLASTIC, P.C.B. R/A FEMALE |
|  UNITS : mm [inch] | APP'D <i>LION</i> | DRAW NO. C505-0004 | |
| | PRODUCT SPEC. — | 505-0014 | SHEET 1 OF 1 |
| SCALE NONE | SIZE A4 | REV. B | 10007 |