

REV.	DESCRIPTION	DATE
—	RELEASE	Dec. 13, 2002
1	DRAW MODIFY	Jan. 17, 2003
2	DRAW MODIFY	Feb. 18, 2003

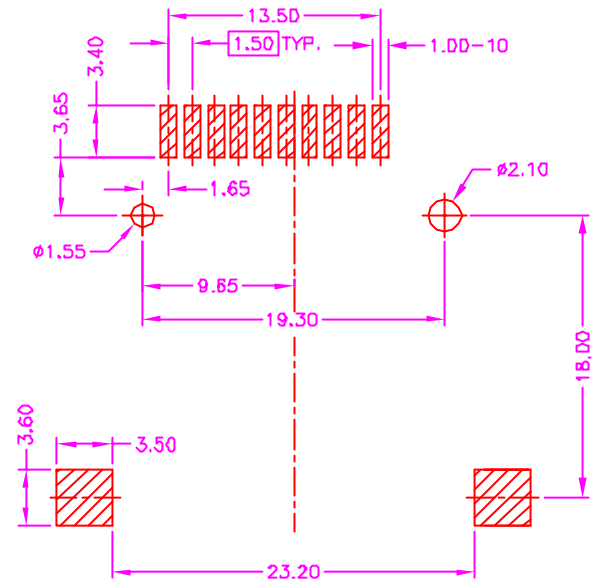
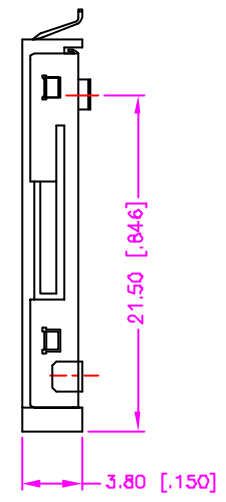
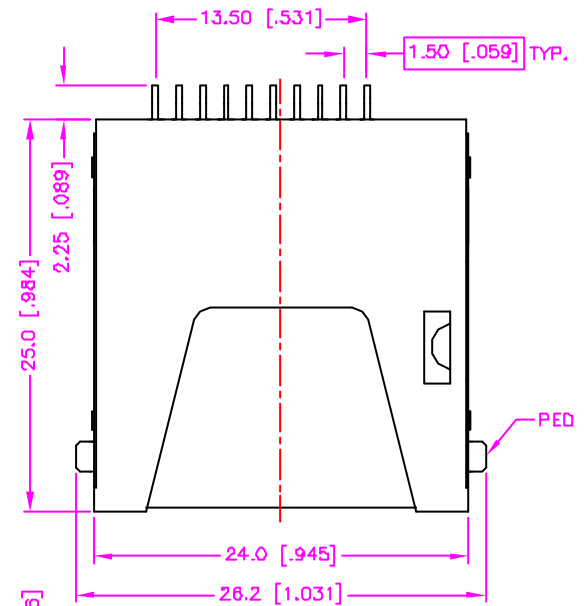

**RECOMMEND P.C.B. LAYOUT
TOP VIEW**

ORDER INFORMATION :

54 - 06 04 - 10 *

SERIES CODE | TYPE 04 | HOUSING COLOR OPTIONS
W : WHITE
BLANK : BLACK
NUMBER OF POSITIONS

MATERIALS

- HOUSING : HI.-TEMP. PLASTIC (UL 94V-0).
- TERMINAL : PHOSPHOR BRONZE, GOLD PLATING ON CONTACT AREA, TIN PLATING ON SOLDER TAIL.
- SHIELD : STAINLESS STEEL, NICKEL PLATING, GOLD PLATING ON PED. (t=0.20mm)

SPECIFICATION

- CURRENT RATING : 0.5 AMP. MAX.
- DIELECTRIC WITHSTANDING VOLTAGE : 500V AC R.M.S. FOR ONE MINUTE.
- INSULATION RESISTANCE : 1000M OHMS MIN. AT 500V DC.
- CONTACT RESISTANCE : 100m OHMS MAX.
- OPERATING TEMPERATURE : -20°C TO +85°C
- MAX. PROCESSING TEMP. : 230°C FOR 30 ~ 60 SECONDS.

TOLERANCE .0=±0.30 [.012] .00=±0.20 [.008] .000=±.XXX .0000=±. ANG.=±3'		DRAWER <i>Katherlin</i>		ASTRON TECHNOLOGY CORP. NAME MEMORY CARD MS READER CONNECTOR P.C.B. MOUNT, 1.50mm PITCH SMT (REVERSE TYPE)
UNITS : mm [inch]		CHECK <i>LTON</i>	APP'D <i>MS</i>	
SCALE NONE	SIZE A4	PRODUCT SPEC. —	—	DRAW NO. C254-0604
SHEET 1 OF 1		REV. C	10019	