

REV.	DESCRIPTION	DATE
—	RELEASE	Sep. 4, 2001
1		
2		

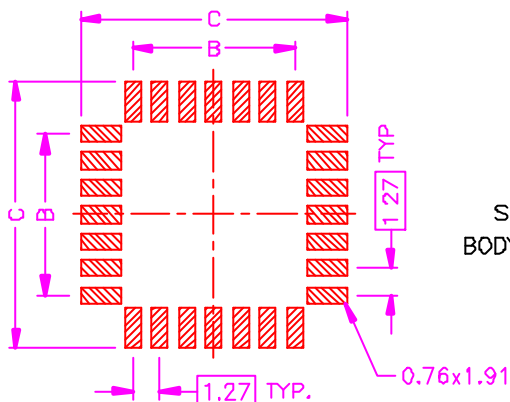
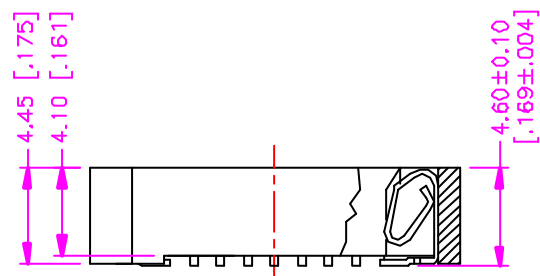
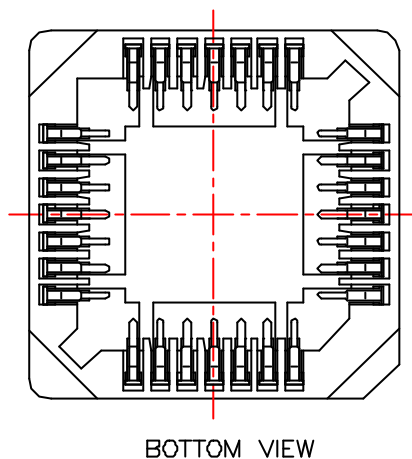
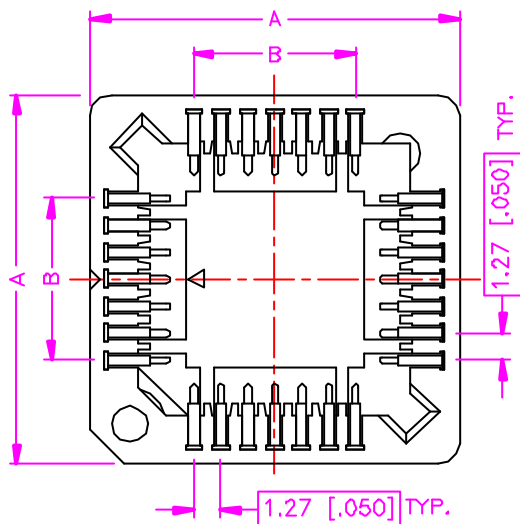

MATERIALS

- HOUSING : HI.-TEMP. PLASTIC (UL 94V-0).
- TERMINAL : PHOSPHOR BRONZE, TIN PLATING.
(t=0.17mm)

SPECIFICATION

- CURRENT RATING : 1 AMP. MAX.
- DIELECTRIC WITHSTANDING VOLTAGE :
600V AC R.M.S. FOR ONE MINUTE.
- INSULATION RESISTANCE : 1000M OHMS MIN.
AT 500V DC
- CONTACT RESISTANCE : 30m OHMS MAX.
- OPERATING TEMPERATURE : -55°C TO +105°C.
- CAPACITANCE : 1PF.
- MAX. PROCESSING TEMP. :
230°C FOR 30 ~ 60 SECONDS.

ORDER INFORMATION

40 - 32 3 1 - ** N - **

SERIES CODE
BODY HEIGHT - 4.60mm
WITHOUT POST

PACKAGE OPTIONS
BLANK : TUBE PACKAGE
TR : TAPE & REEL PACKAGE
BROWN IN HOUSING COLOR
TOTAL NUMBER OF POSITIONS

TOTAL NO. OF POS.	DIMENSIONS			TOLERANCE .0=±.30 [.012] 00=±.20 [.008] 000=±.XXX 0000=±. ANG.=±3°	DRAWER <i>Katherlin</i> CHECK <i>JUS</i> APP'D <i>ALB</i> PRODUCT SPEC. —	ASTRON TECHNOLOGY CORP. NAME PLCC SOCKET 1.27mm PITCH, P.C.B. MOUNT SMT TYPE
	A	B	C			
20	14.86 [.585]	5.08 [.200]	10.03 [.040]	UNITS : mm [inch]	206-0011	DRAW NO. C240-3201
28	17.40 [.685]	7.62 [.300]	12.57 [.495]			
44	22.48 [.885]	12.70 [.500]	17.65 [.695]	SCALE NDNE	SIZE A4	SHEET 1 OF 1
52	25.40 [1.000]	15.24 [.600]	20.19 [.795]			
68	30.54 [1.202]	20.32 [.800]	25.27 [.995]	REVISION A	REV. A	09008
84	35.56 [1.400]	25.40 [1.000]	30.35 [1.165]			